

# Automation

for the plastics industry



Extrusion professionals for over 40 years

PLAST-CONTROL

FOR OVER

40  
YEARS

WE HAVE BEEN AUTOMATING  
EXTRUSION PROCESSES

# A success story

PLAST-CONTROL has been automating extrusion processes and since its foundation in 1979, has continuously developed new technologies and standards and established them on the market.

Early on, we specialized in the equipment of blown film and are now the leading manufacturer in this field. Meanwhile, about 30% of the systems are also supplied to other areas of the plastics industry - for example, in the production of cast films, sheets, tubes, spunbonded nonwovens or injection molding.

We produce exclusively in Germany and supply our products worldwide. Our branch offices in the USA, Great Britain, India, China and Taiwan as well as our representations in countries on all continents ensure a smooth, global distribution.

### Our employees, our greatest asset!

We rely on high-tech, high quality workmanship as well as comprehensive and fast customer support by our service team.

This is only possible with qualified and motivated employees who are interested in new developments. Therefore, investments in our personnel are investments in the future - and to our client's best interest.



MORE THAN  
**24.000**  
SYSTEMS INSTALLED  
WORLDWIDE

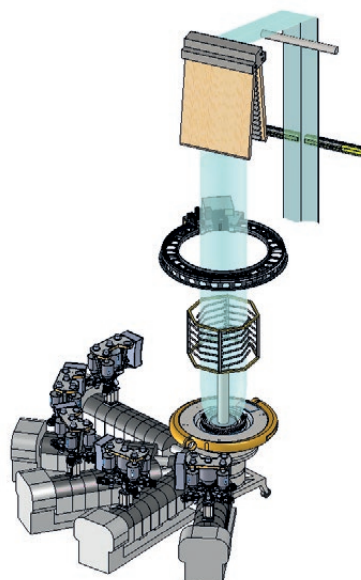

● Branch offices  
● Representations



ON  
**6.000** m<sup>2</sup>

OVER 100 EMPLOYEES WORK AT THE HEADQUARTERS IN REMSCHEID



**Table of contents**

About PLAST-CONTROL ..... 2

**Systems**

GT3 & ACS..... 7

NAVIGATOR ..... 8

**Dosing**

PRO-GRAV with PRO-DOS ..... 10

PRO-BATCH ..... 12

PRO-CLEAN & PRO-DRAIN ..... 13

**Vacuum conveying**

PRO-VAC ..... 15

**Profile measurement**

PRO-FIL ..... 17

PRO-WIDE ..... 18

**Profile control**

PRO-CON, -DUO II & -Flex ..... 20

**Special solutions**

Central vacuum ..... 23

PIPE-IDENT & PCH-E ..... 24

PCC ..... 25

PRO-SONIC, PRO-CAGE ..... 26

PRO-LAB II ..... 27

”

We've been using PLAST-CONTROL gravimetric systems and automatic gauge control systems successfully in our plant at Aristocrat Industries Ltd, Nigeria. Its precise control allowed us to continuous supply the best quality of extrusion film to our customers. We really appreciate PLAST-CONTROLs contribution to our business success.

**Bibhash Ghosh, Maintenance Manager,  
Aristocrat Industries Ltd, Nigeria**

# Automation & Quality assurance

PLAST-CONTROL is the only company in the industry to manufacture all required components in-house.

Do you know a more efficient partner who is always at your disposal - from material supply to gravimetric dosing with extruder control, temperature control, IBC control, cooling ring technology, profile measurement and profile control up and to special custom solutions in process engineering?

PLAST-CONTROL can fully automate your extrusion line. Do not hesitate to contact us!

- 1 Central operating station
- 2 Material conveying (vacuum loading) with intelligent control
- 3 Gravimetric throughput, measurement and control systems
- 4 Thickness tolerance control, own cooling ring technology
- 5 PRO-SONIC bubble control
- 6 Calibration basket PRO-CAGE
- 7 IBC, internal bubble cooling
- 8 Online thickness measurement
- 9 Haul-off measurement and haul-off control
- 10 Width measurement

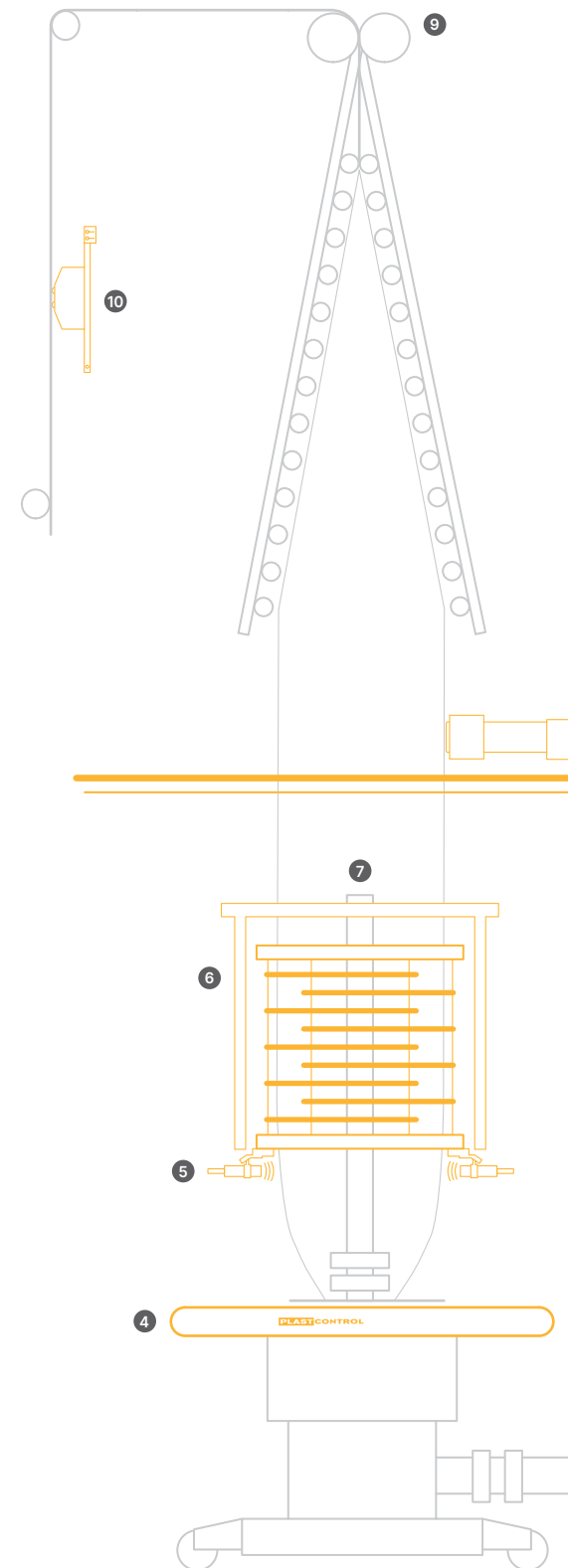

”

The current project is my first experience with PLAST-CONTROLs auto thickness control and other equipment. We really appreciated the way PLAST-CONTROL India as well as their German counterpart immediately responded to my issue and quickly resolved it. This also hugely built confidence in PLAST-CONTROLs products and services. We especially value their technical support and service team for their time-to-time support extended in past. I personally am convinced that the cooperation with PLAST-CONTROL and their equipment are top value for money. We are looking forward to our future cooperation.

**Anil Dimri, Vice President Operations,  
Shree Maa Roll Wrap P LTD & Spack Laminators, India**

”

The Plastilene group is always looking for more than suppliers, business partners with whom to grow hand in hand, based on the high reliability of the equipment purchased and the good business relationship. That is why PLAST-CONTROL is one of our strategic partners in our plastic film extrusion processes.

**Mauricio Hernando Muños Cubillos,  
Engineering and Maintenance Manager,  
Plastilene, Colombia**

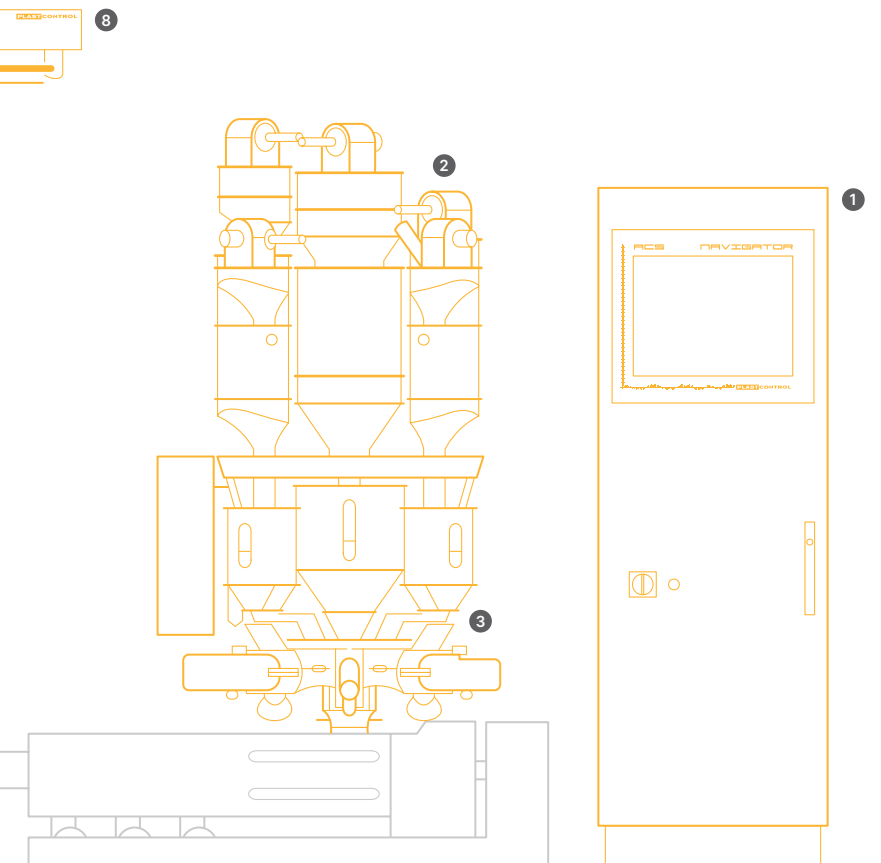

#### YOUR ADVANTAGE

- waste reduction and raw material savings
- fast changeover times
- reproducibility of products
- higher outputs
- transparent production and cost control
- complete automation from a single source
- avoidance of operating errors



# GT3 & ACS

We offer complex systems for gravimetric control and dosing as well as for improvement of the film profile. All PLAST-CONTROL systems can be modularly extended and thus individually adapted.



### GT3 - low-cost and powerful

The system for gravimetric control of an extrusion line, designed for weighing a maximum of three hoppers. The GT3 is also used for systems that do not require extensive visualization, such as:

- Stand alone conveying
- Width control
- IBC control



### ACS - the all-rounder

The ACS is characterized by the simultaneous handling of all functions described so far.

The generous display of all processes on a 19" TFT touchscreen display makes operation particularly clear and convenient.

The best solution for systems that do not require extensive visualization

Optionally the ACS can be installed in an existing cabinet

”

*PLAST-CONTROL provides a stable and precise control for complete blown film lines. More important, their products – especially the IBC control system – are very easy for our operators to handle. We also value their responsive after sales service in our daily business.*

Queen's Machinery, Taiwan

### YOUR ADVANTAGE

- capacitive online thickness measurement
- width measurement and control
- IBC control
- conveyor control



Further information as well as additional images and graphics can be found on our website

## LINE CONTROL

# NAVIGATOR

The NAVIGATOR control system makes it possible to manage all plant components easily and conveniently via touch screen. Whether retrofitting or a new plant - the NAVIGATOR can be quickly and easily adapted to all-around concepts thanks to its modular design.

Long-term and complete service  
on all our products

In good hands:  
Comprehensive technical  
and legal advice

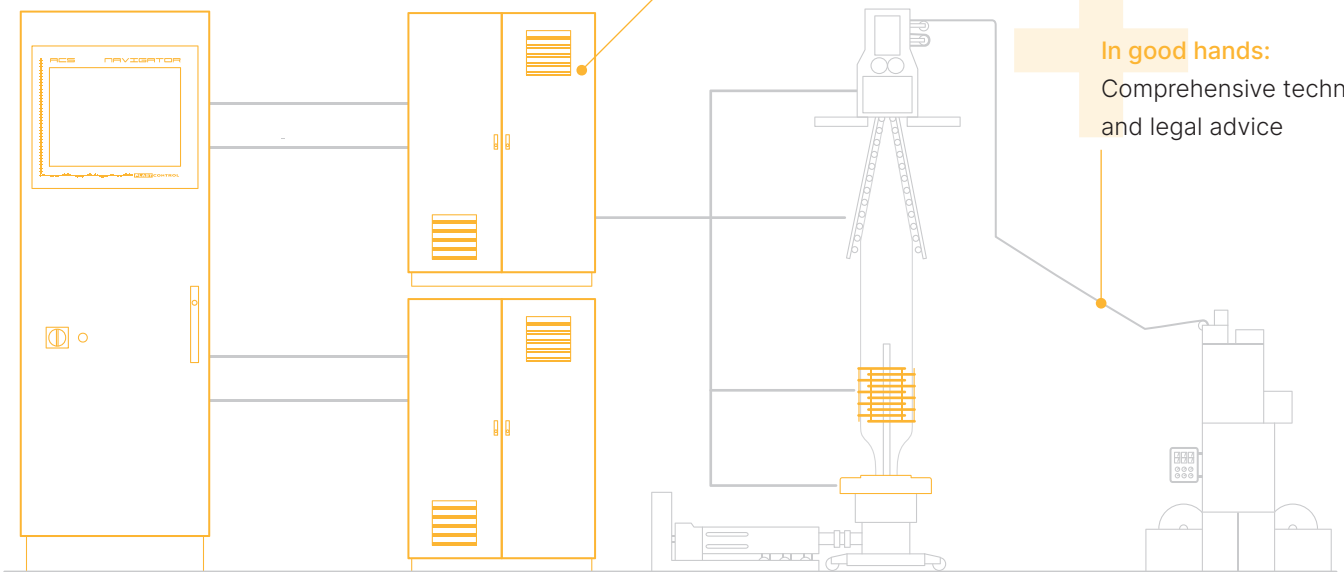

## YOUR ADVANTAGE

- Modularity
- Safety functions
- Retrofit or exchange of the old components
- Long-term spare parts supply
- Operation via touch screen
- Implementation of individual customer requirements
- Project handling from a single source
- Control cabinet construction or retrofit



Independent of market common cycle times  
and difficult spare parts supply due to  
in-house production of hardware and software



Further information as well as additional images and graphics can be found on our website



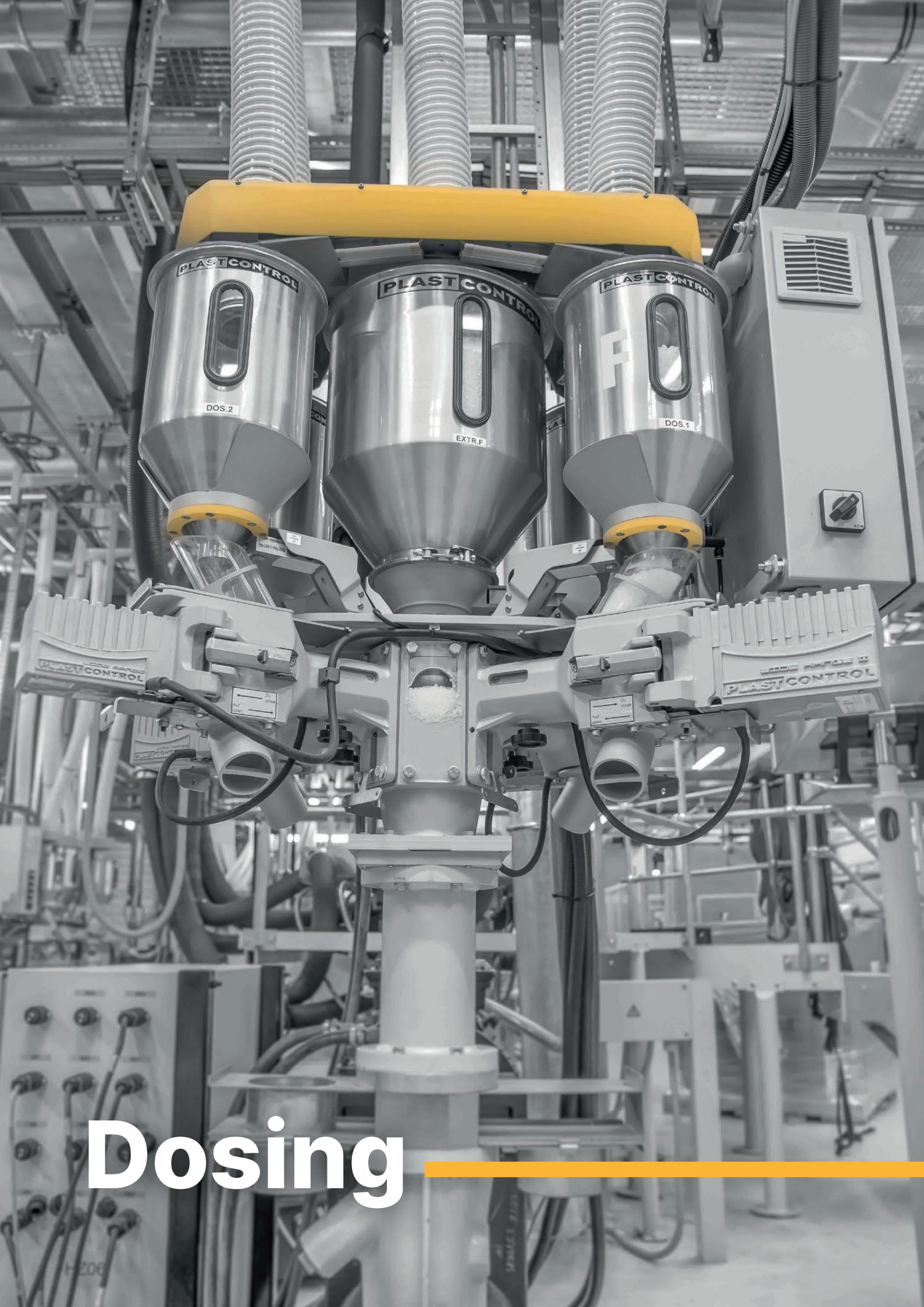

# Dosing

---

# PRO-GRAV with PRO-DOS

The basis of extrusion line automation has been gravimetric extruder control for over 40 years. The control concept can be used for all continuous extrusion processes. A gravimetric weigh hopper frame, a slide valve and a PC system are required.

Measurement according to the „loss-in-weight“ principle guarantees precise throughput determination, independent of the bulk density

## PRO-GRAV

In co-extrusion lines, the layer thickness is controlled by adjusting the individual extruder throughput while taking the target value into account. If the production level is increased, all extruders are synchronized and the product specifications are maintained even during the changeover phase.

## PRO-DOS

Various demands on the end product often require the use of several material types per extruder. The best technical solution for dosing expensive additives as economically as possible is continuous gravimetric dosing, in which the additives are fed into the main material flow via the extruder feeder.

- Arrangement prevents segregation
- Control of all feeders synchronously with the extruders

Target value deviations are detected by the system and readjusted accordingly

New generation dosing motors with wide speed range and high torque eliminate the need for screw changes



Retrofitting your lines with PRO-GRAV is also possible. Please contact us!

**The micro feeders**

follow the trend towards more and smaller dosing quantities. A minimum of about 100g/h is possible with good dosing accuracy



**Modular design**

Connection of up to seven gravimetric dosing units possible

**YOUR ADVANTAGE**

- raw material and aggregate savings (up to 4% possible)
- no dependence on bulk weight
- quick changeover times
- no premixed material
- accuracy of 0,1%
- constant product quality
- simple target value control
- robust, durable design
- up to 8 materials per extruder
- No dosing screw changes necessary
- easy cleaning
- fast ROI



Further information as well as additional images and graphics can be found on our website

## GRAVIMETRIC BATCH DOSING

# PRO-BATCH

Compared to continuous dosing, a batch mixer works according to the „gain-in-weight“ principle when producing the mixture. Here, material gates are opened for a pre-calculated time and the weight increase is registered in the weighing chamber. When the batch is complete, the material is discharged into the mixing chamber and mixed.

- effective helix mixer
- easy handling
- easy cleaning
- cost effective

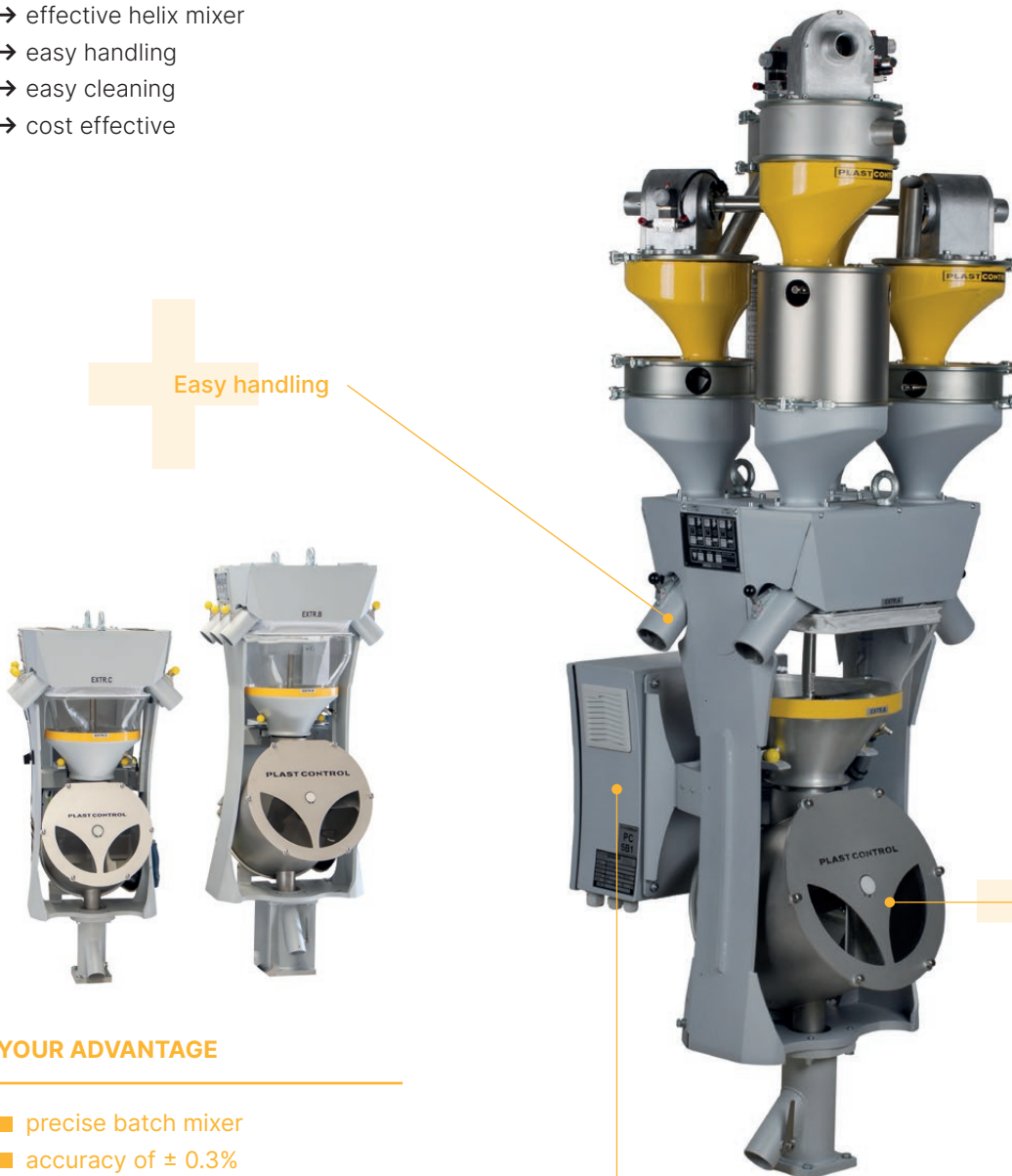

Easy handling

The mixing hopper operates as a gravimetric weighing hopper in the „loss-in-weight“ process for extruder control

Versatile and flexible

for four or six materials and different throughputs

### YOUR ADVANTAGE

- precise batch mixer
- accuracy of  $\pm 0.3\%$
- compact design
- versatile use
- good accessibility



Further information as well as additional images and graphics can be found on our website

Model	PB4-180	PB4-450	PB6-150	PB6-300
No. comp.	4	4	6	6
Max. output kg/h	180	450	150	300

# PRO-CLEAN & PRO-DRAIN

Impurities often lead to defects in the produced film and thus to a higher scrap rate. PLAST-CONTROL has developed a new integrated solution for a cleaner gravimetric dosing process and a fully automatic sequence process for less material loss during job changes.

## PRO-CLEAN

works with a new conical weighing hopper that replaces the classic „slide design“ with its large dead zones. All internal hopper surfaces are continuously self-cleaned by flowing granules.

- complete filling in one conveying step
- precise weighing

## PRO-DRAIN

With PRO-DRAIN, all gravimetric dosing units can be cleaned automatically at the end of a job.

- manual connection of the material line to the new material bin/silo
- the rest is done automatically



During job changeover, only a minimum of material remains in the hoppers

No dead-zones refilling prevents dust loading and contamination

## YOUR ADVANTAGE

- minimized downtime
- raw material savings
- reduction of scrap rate
- clean hoppers at all times
- no more dead zones in conveyors/hoppers



Further information as well as additional images and graphics can be found on our website



# Vacuum conveying

---

# PRO-VAC

Every extrusion process starts with conveying the materials to the line. The right design guarantees high availability, lowest dust formation and energy efficiency with maximum flexibility.

## The decentralized principle

Each component is equipped with its own material conveyor. As soon as the conveyor signals a material requirement to the system, a valve is switched promptly and the conveyor is put under negative pressure via a vacuum pump with a central pre-filter. The conveyor can now only suck in air via the material line. The desired material is transported along with the sucked-in air.

## The central conveying principle

In this case, several conveyors can simultaneously transport material. This requires a more powerful pump, but in most cases smaller conveyors can be used.



## Individual components

suction in small quantities over short distances is just as possible as ...



## ... suction with a central vacuum system

over the entire production hall - we always have the right solution

## YOUR ADVANTAGE

- low abrasion design
- high flexibility
- central control



Further information as well as additional images and graphics can be found on our website

# Profile measurement





PROFILE MEASUREMENT

# PRO-FIL

For many years PLAST-CONTROL has been manufacturing its own capacitive measuring sensors for the online thickness measurement of films.

**Non-contact measurement sensor**

The patented AirCC measuring head is specially designed for sticky and surface-sensitive films. In addition to the film thickness, the AirCC also measures the existing air gap (also permanently changing).

**Capacitive measurement sensor**

Capacitive measuring sensors, in conjunction with directly driven scanner rings in lightweight design, ensure a low-maintenance and slip-free measuring cycle.

**New solutions for barrier and cast film**

The new C-SCAN offers a pioneering capacitive measurement for barrier films. PA and EVOH films that could not previously be measured capacitively can now be measured.

**Durable and robust industrial design for non-adhesive films**

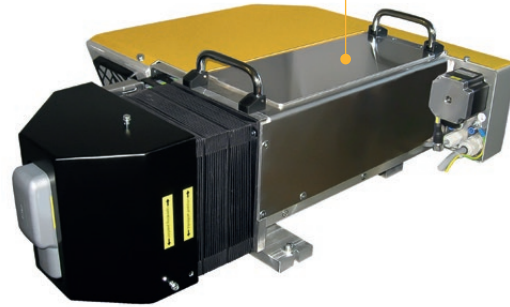

**Insensitive to** temperature fluctuations and strongly adhesive surfaces

**Patented solution** for sticky films

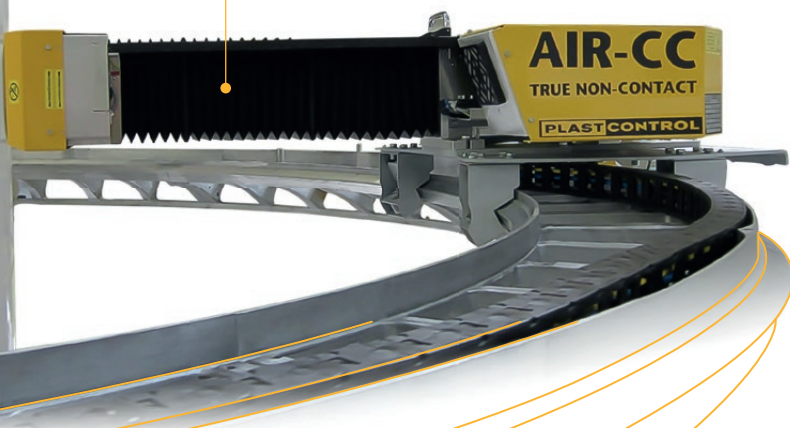

**YOUR ADVANTAGE**

- The right measurement for every application
- sticky (EVA) and soft films can be measured
- integrated film temperature measurement
- barrier film measurement with new C-scan system
- non-contact measurement of overall thickness



Further information as well as additional images and graphics can be found on our website

## WIDTH CONTROL

# PRO-WIDE

For films with side gussets, a width measurement can possibly be carried out via the ultrasonic sensors of the IBC. For films without side gussets, a separate width measurement is required.

Here, a width measuring bar is installed between the flat lay and the winder. Width fluctuations are compensated by a diameter adjustment of the calibration basket and the IBC control. The measurement precisely detects the edges of the film.

### Any shrinkage

is largely completed at the measuring point

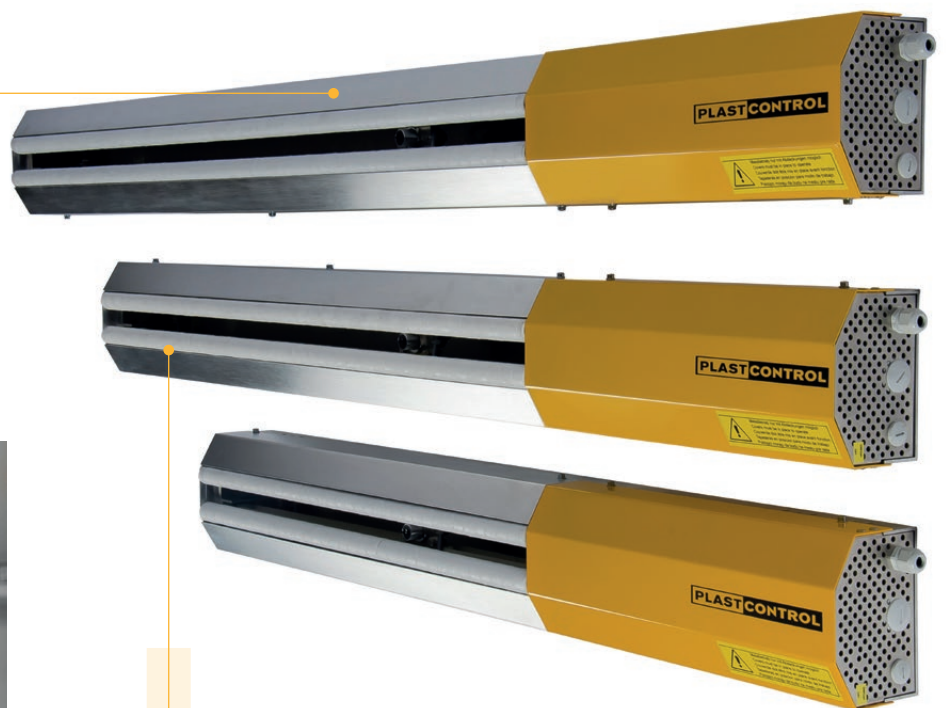

### The width measurement

is taken shortly before the winder and thus corresponds exactly to the width on the film wrap

## YOUR ADVANTAGE

- precise width control
- various roller surfaces
- torsion-resistant design
- wide range of applications



Further information as well as additional images and graphics can be found on our website

# ”

*The entire PLAST-CONTROL team is very supportive and always ready to assist, no matter what the problem or the given time requirements. Our cooperation with PLAST-CONTROL has always been very positive and encouraging for us.*

**Rahul Agrawal, Managing Director,  
Shiv Shakti Packaging Pvt. Ltd., Nepal**

# Profile control

**PLAST CONTROL**

**PRO-CON DUO**



BETTER REGULATING AND COOLING WITH

Easy  
retrofit!

# PRO-CON, -DUO II & -FLEX

In addition to the actuator used, fast and accurate software is crucial for reducing the transverse tolerances on blown films.

## PRO-CON

The PRO-CON profile control works with an automatic, segmented cooling ring that regulates the volume of the two cooling air streams and thus achieves an influence on the film thickness.

## YOUR ADVANTAGE

- 50% reduction of the base tolerances
- no additional energy input into the film
- increased output due to MAGIC FLOW
- simultaneous control on thin and thick sections
- rotating/oscillating dies can be retrofitted
- auto profile shift compensation



## Various models to choose from

The cooling rings are available in three sizes

TYPE	Model	Die Ø mm
PRO-CON	C-200/32	80-200
PRO-CON	C-400/48	200-400
PRO-CON	C-750/64	400-750

**Improved air flow**

and modified geometries allow work with significantly higher air volumes and air speeds



**Performance increases of up to 40%** are possible compared to conventional, modern double-lip cooling rings

**Existing thin spots in the film**

are cooled more directly when the melt exits the die and can therefore no longer expand as much. The film remains thicker at this point

**On thick spots in the film**

PRO-CON reacts accordingly in the opposite direction. Depending on the raw material and product handling, the film circumference tolerance is reduced to a possible minimum

**PRO-CON DUO II**

An additional increase in output is possible with the PRO-CON DUO II double cooling ring. In addition to the output, the mechanical properties of the film are also significantly improved. Electric height adjustment and optimized geometry make handling child's play.

**YOUR ADVANTAGE**

- high output, fast return of investment
- best film tolerances
- better film strengths
- versatile use
- high BUR range, e.g. from 1:1.3 to 1:5

**PRO-CON FLEX**

The new automatic high-performance cooling ring allows significantly faster and more precise influencing of the cross-profile tolerances of the film. This is made possible by modulating the air flow via a flexibly deformable medium directly at the outlet of the secondary lip. Currently available in 2 sizes (die diameters from 200 - 850 mm).

**YOUR ADVANTAGE**

- dynamic, more precise and transitionless control
- no overlapping of air flows
- significant reduction in the amount of plastic used and energy consumption
- considerably improved film properties



**Further information** as well as additional images and graphics can be found on our website

# Special solutions



# Central vacuum

More and more extrusion plants are centralizing the vacuum system needed to convey raw materials from the silos to the machines.

For this purpose, several powerful vacuum pumps and corresponding pre-filters are installed in a closed room. The entire production hall is supplied with vacuum via a central pipeline.

In addition to the diverse hardware solutions for vacuum supply, PLAST-CONTROL offers intelligent software solutions. Material Minimizing Control (MMC) ensures that the storage bins are already completely empty during a changeover and that only a small amount of material remains in the weighing hopper.

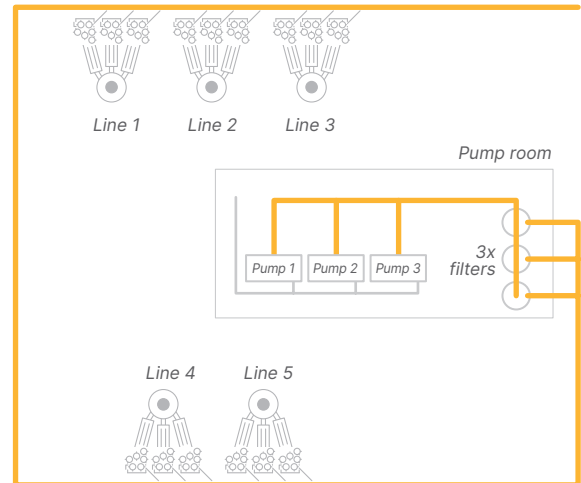

## The advantages of centralized vacuum production

Energy efficiency, workplace-appropriate noise protection and significantly increased performance at lower investment costs

## YOUR ADVANTAGE

- Noticeable lower energy consumption
- high flexibility
- increased availability
- reduced maintenance effort
- centralized control
- no dust contamination in the production hall
- noise prevention in the production hall

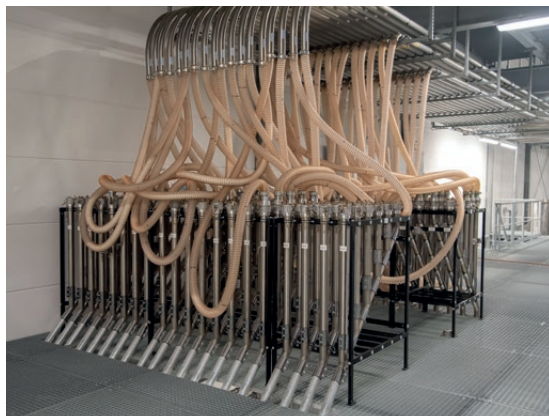

Further information as well as additional images and graphics can be found on our website

SOLVE PROBLEMS WITH

# PIPE-IDENT & PCH-E

## Coupling detection PIPE-IDENT

Faulty coupling of material feed hoses is made largely impossible with PIPE-IDENT.

The removable flex hose is provided with a fixed coding, the rigid side is coded via a cable and a computer. If the flexible side is now coupled with an incorrect mating part, an alarm message appears. The identification of each closed coupling is done through short-range transmission.



## YOUR ADVANTAGE

---

- high customer binding
    - reduction of production errors
  - unique feature with integration in SCADA system
  - no suction if incorrectly coupled
  - Comparison of recipe on machine with material types in the silos
- 



Further information as well as additional images and graphics can be found on our website



## Dust separation with PCH-E

Dust and contamination of the virgin material often cause problems in the extrusion process. Especially long transport distances between the silos and the machines with many elbows generate angel dust and angel hair that should be filtered before entering the extruder by using filtration devices. For this type of problems, there are many solutions available - just ask our engineers.

## YOUR ADVANTAGE

---

- high transparency
  - energy efficiency
  - customized design
  - high reliability
  - efficient filtering of dust and angel hair
-



REAL TIME PLANT-WIDE MONITORING WITH

# PCC

We can provide you with a useful and practical basic package with standard evaluations. Individual customizations are also possible.

The plant-wide networking of all extrusion lines with PCC creates a previously unimaginable transparency of all actual processes in production - in real time!

Centrally, on a PC, all existing production data of each plant are made visible online. With PCC it is very easy to carry out a complete material database, quality control, data backups, production controls and work preparations.

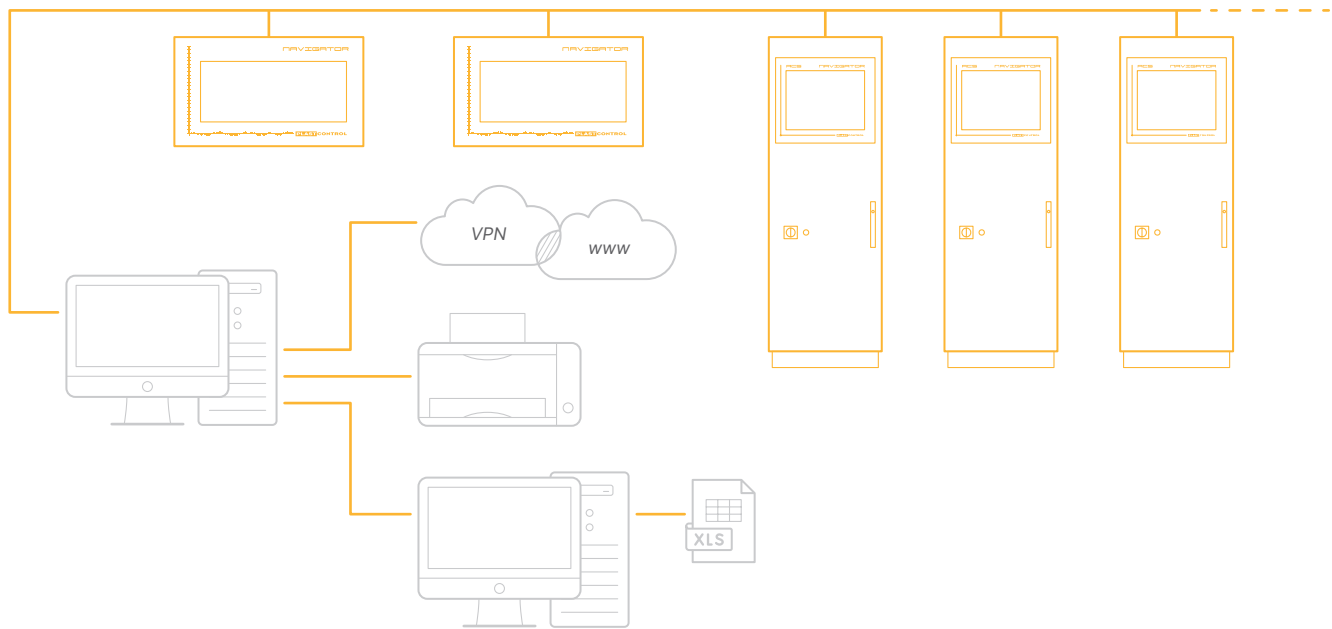

**YOUR ADVANTAGE**

- OEE (Overall Equipment Efficiency)
- real-time production transparency
- material database capability
- central data backup
- online access to all production parameters
- scrap accountability
- central logging of machine status and alarms
- remote maintenance
- integration into your plant network

”

The collaboration with PLAST-CONTROL goes back nearly two decades, in fact, we introduced PLAST-CONTROL in India after a global search for a partner for automation for our blown film lines. The innovations in automation for the blown film technology are very beneficial for us as a machinery manufacturer as well as for our customers. The after-sales-support is for us an important aspect of a business relationship. The fact that PLAST-CONTROL offers this type of support on-site in India is a key confidence factor for both ourselves and our customers. We do look forward to further strengthening our relationship with PLAST-CONTROL.

Yogesh Joshi, Head Technical Purchase,  
Rajoo Engineers Ltd., India



Further information as well as additional images and graphics can be found on our website

## IBC BUBBLE CONTROL

# PRO-SONIC

PRO-SONIC can be implemented in any PLAST-CONTROL system. Three ultrasonic sensors are used for non-contact measurement.

Replacing an existing IBC control system often makes sense, as today's systems are non-contact, much more precise and respond faster. This saves edge trim width and minimizes scrap.



### YOUR ADVANTAGE

- central operation
- cost-effective use of existing computer capacities
- contact-free measurement



Thanks to highly accurate ultrasonic sensors and a control valve, we are able to achieve width variations of less than +/- 2 mm even on existing systems



Further information as well as additional images and graphics can be found on our website

## CALIBRATION BASKET

# PRO-CAGE

The PRO-CAGE calibration basket is an extremely important component for the manufacturable quality of a film.

It is characterized by a very stable and intelligent design and a wide range of applications. Various attachments for the calibration rollers allow flexible adaptation to the respective film requirements.

Available in various designs, also as a scissor-type calibration



# PRO-LAB II

The PRO-LAB II is equipped with a touching sensor for the absolute measurement of film profiles according to the norms DIN 533370/ ISO 4593/ ASTM-D 6988-08.

The analysis is carried out via a film strip, the measured value acquisition with a mechanical detection head, which automatically carries out the measurement at selectable intervals. The stepwise advance of the film strip is ensured by a maintenance-free stepper motor. Meaningful profile graphics, average values, maximum and minimum values facilitate the detection of setpoint deviations.



## YOUR ADVANTAGE

- standardised measurement according to DIN/ISO
- easy handling
- automated measurement
- easy calibration
- incl. serial interface



Further information as well as additional images and graphics can be found on our website

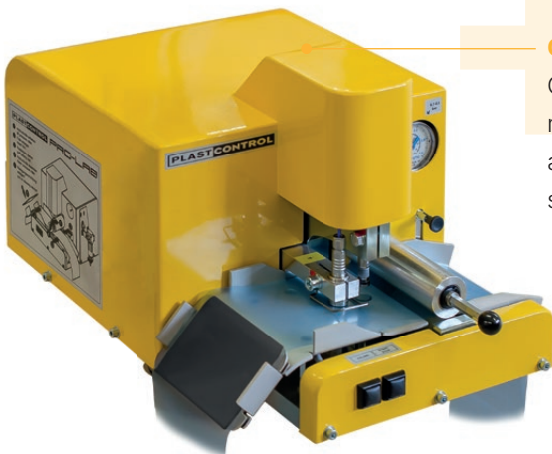

### Optional

Operation in continuous mode possible with an additional capacitive sensor

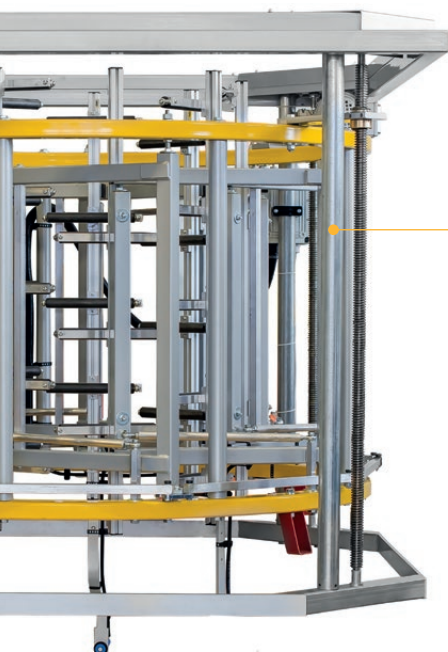

### Flexibly adaptable

to the requirements of the respective film

## YOUR ADVANTAGE

- precise width control
- various roller surfaces
- rigid design
- wide range of applications



Further information as well as additional images and graphics can be found on our website



**Visit our website**

**PLAST-CONTROL GmbH** Walter-Freitag-Str. 15, 42899 Remscheid · Germany  
Tel. +49 2191 9480-0 · Fax +49 2191 9480-49

**PLAST-CONTROL Ltd.** Unit 17, Leeward Road · Ashton-Preston · Lancashire Pr2 2te · Great Britain  
Tel. +44 1772 769963 · Fax +44 1772 736357

**PLAST-CONTROL Inc.** 65 Parker Street, Unit 10 · Newburyport, Ma 01950 · USA  
Tel. +1 978 462 0306 · Fax +1 978 462 1425

**PLAST-CONTROL Asia Ltd.** 7f, No. 155, Keelung Road · Sec. 1, Xinyi District · Taipei City, 110 · Taiwan  
Tel. +886 2 3765 1808 · Fax +886 2 2767 2538

**PLAST-CONTROL China Co. Ltd.** Unit 53 · Floor 11 · No. 6088 Humin Road · Shanghai  
Tel. +86 21 5413 3383 · Fax +86 21 5413 3323

**PLAST-CONTROL India Pvt. Ltd.** (Office in MUMBAI) B Wing · G -8 Kemp Plaz · Ram Nagar  
Mindspace · Malad (West) Mumbai 400064 · Maharashtra · India  
Tel. +91 95940 33303

**PLAST-CONTROL India Pvt. Ltd.** (Office in AHMEDABAD) C-806 · Rajyash Rise Business Park  
NH 64 · Near Vishalla Hotel · Ahmedabad 380007 · Gujarat · India  
Office Tel. +91 79 46027251 · Tel. +91 96876 40089